

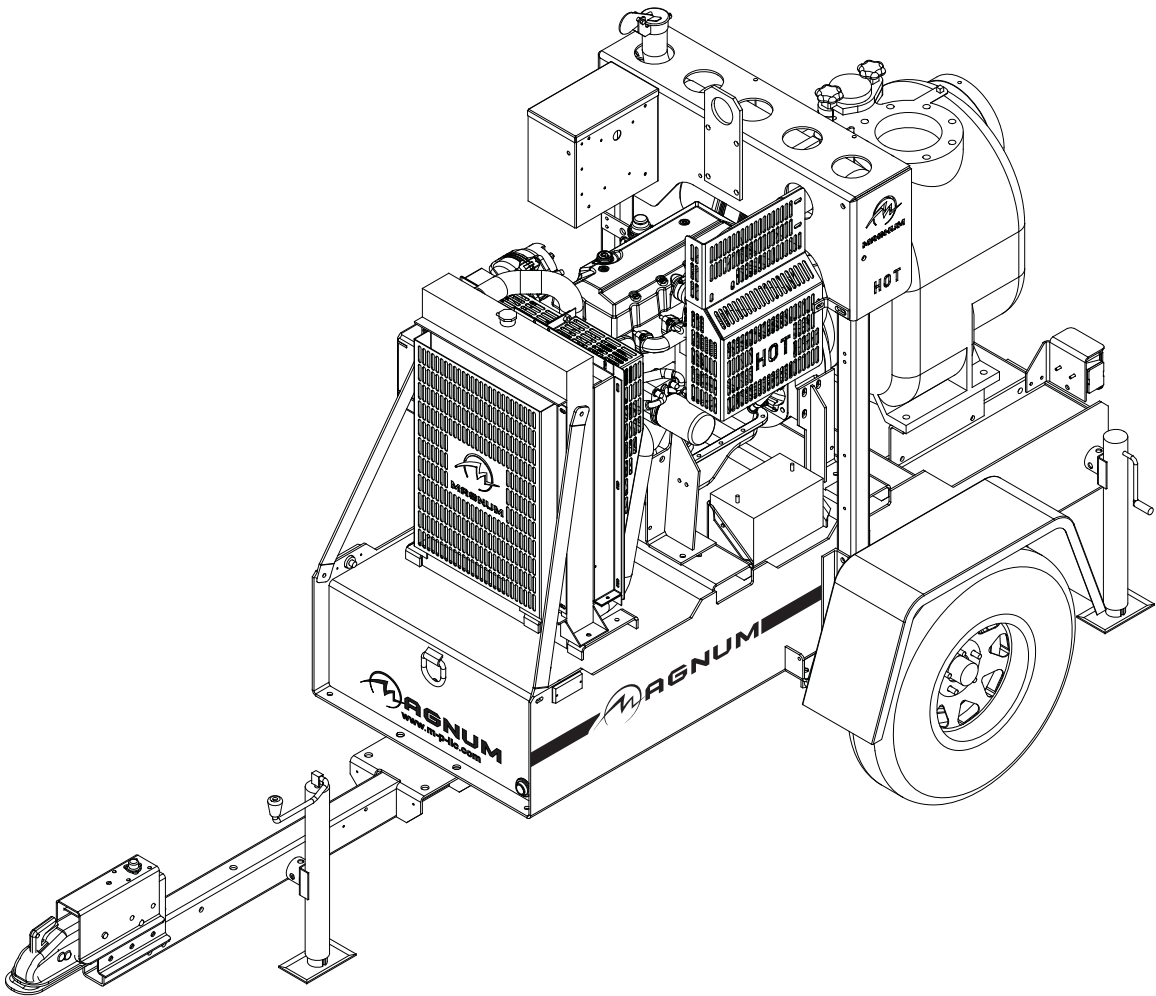

SELF-PRIME DIESEL TRASH PUMP
MTP4000S • MTP6000S



OPERATING MANUAL

INTRODUCTION

This manual provides information and procedures to safely operate and maintain the engine and pump. For your own safety and protection from physical injury, carefully read, understand, and observe the safety instructions described in this manual. *The information contained in this manual was based on machines in production at the time of publication. Magnum Products LLC reserves the right to change any portion of this information without notice.*

DO NOT MODIFY or use this equipment for any application other than which it was designed for.

Magnum Products LLC recommends that a trained and licensed professional perform all electrical wiring and testing functions. Any wiring should be in compliance with the United States National Electric Code (NEC), state and local codes and Occupational Safety and Health Association (OSHA) guidelines.

Keep a copy of this manual with the unit at all times. Additional copies are available from Magnum Products LLC, or can be found at www.m-p-llc.com. An engine operator's manual was also supplied with the unit at the time of shipment from the factory. The manual provides detailed operation and maintenance procedures for the engine. Additional copies of the engine operators manual are available from the engine manufacturer.

MAGNUM PRODUCTS LLC
215 Power Drive • Berlin, WI 54923
U.S.A.
Phone: 920-361-4442
FAX: 920-361-4416
Toll Free: 1-800-926-9768
www.m-p-llc.com

For technical or parts QUESTIONS, please contact Magnum Products' Customer Support or Technical Support team at 920-361-4442. Please have your serial number available.

To ORDER SERVICE PARTS, please contact the dealer from which you purchased the unit, or call Magnum Products to locate a dealer in your area.

Engine Make: _____
Engine Serial Number: _____
Engine Model Number: _____
Pump Make: _____
Pump Model Number: _____
Pump Serial Number: _____
Unit Model Number: _____
Unit Serial Number: _____

▲ WARNING

CALIFORNIA PROPOSITION 65 WARNING: Diesel engine exhaust and some of its constituents are known to the state of California to cause cancer, birth defects and other reproductive harm.

TABLE OF CONTENTS

	Page
INTRODUCTION	2
TABLE OF CONTENTS	3
SAFETY NOTES	4
OPERATING SAFETY	4
ENGINE SAFETY	5
SERVICE SAFETY	5
TOWING SAFETY	6
REPORTING TRAILER SAFETY DEFECTS	6
SAFETY SYMBOL SUMMARY	7
LOCATIONS AND CONTROLS	8
UNIT SERIAL NUMBER LOCATIONS	9
SPECIFICATIONS	10
MAIN CONTROL PANEL	11
CONTROL PANEL LEDS	12
PRE-USE CHECKPOINTS	13
PUMP SET UP	13
STARTING THE PUMP	14 - 16
SUCTION SPECIFICATIONS	17
STOPPING THE PUMP	17
AUTOMATIC SHUTDOWN	17
REMOTE/AUTO STARTING	17
ENGINE AND PUMP MAINTENANCE	18
ENGINE BREAK-IN REQUIREMENTS	18
OIL SIGHT GLASS	18
DAILY WALK AROUND INSPECTION	19
BELT TENSION	19
MAINTENANCE SCHEDULE	19
TOWING THE TRAILER	20
TRAILER WHEEL BEARINGS	20
LIFTING THE PUMP	20
TROUBLESHOOTING	21 - 22
TRAILER LIGHTS WIRING DIAGRAM	23
DC WIRING DIAGRAM	24
SERVICE LOG	25
NOTES	26

SAFETY NOTES



This is the safety alert symbol. It is used to alert you to potential personal injury hazards. Obey all safety messages that follow this symbol to avoid possible injury or death.

This manual contains DANGERS, WARNINGS, CAUTIONS, NOTICES and NOTES which must be followed to prevent the possibility of improper service, damage to the equipment, personal injury or death. The following formatting options will apply when calling the readers attention to the DANGERS, WARNINGS, CAUTIONS, NOTICES and NOTES.

▲ DANGER

INDICATES A HAZARDOUS SITUATION WHICH, IF NOT AVOIDED, WILL RESULT IN DEATH OR SERIOUS INJURY.

▲ WARNING

Indicates a hazardous situation which, if not avoided, could result in death or serious injury.

▲ CAUTION

Indicates a hazardous situation which, if not avoided, may result in minor or moderate injury.

NOTICE

Indicates a hazardous situation which, if not avoided, may result in property or equipment damage.

Note: Notes contain additional information important to a procedure and will be found within the regular text body of this manual.

OPERATING SAFETY



Before using the pump be sure you read and understand all of the instructions! This equipment was designed for specific applications; DO NOT modify or use this equipment for any application other than which it was designed for. Equipment operated improperly or by untrained personnel can be dangerous! Read the operating instructions and familiarize yourself with the location and proper use of all instruments and controls. Inexperienced operators should receive instruction from someone familiar with the equipment before being allowed to operate or set up the pump. The following points should be practiced at all times:

- The area immediately surrounding the pump should be dry, clean, and free of debris.
- Position and operate pump on a firm, level surface.
- **NEVER** start a unit in need of repair.
- **NEVER** modify the pump or use it in a manner other than for what it was designed.
- **NEVER** let the pump run dry.
- Do not start the pump if any panels or guards are loose or missing.
- Move the engine start switch to the "OFF" position when servicing or troubleshooting.
- Use hearing protection if you will be near an operating pump for an extended period of time.
- Keep clear of pump suction and discharge openings while pump engine is running.

ENGINE SAFETY



Internal combustion engines present special hazards during operation and fueling! Failure to follow the safety guidelines described below could result in severe injury or death. Also read and follow all safety warnings described in the engine operators manual. A copy of this manual was supplied with the unit when it was shipped from the factory.

- **DO NOT** run engine indoors or in an area with poor ventilation unless exhaust hoses are used. Diesel engine exhaust contains carbon monoxide, a deadly, odorless and colorless gas which, if inhaled, can cause nausea, fainting or death. Make sure engine exhaust cannot seep into closed rooms or ventilation equipment.
- **DO NOT** fill fuel tank near an open flame, while smoking, or while engine is running. **DO NOT** fill tank in an enclosed area with poor ventilation.
- **DO NOT** operate with the fuel tank cap loose or missing.
- **DO NOT** operate on a combustible surface.
- **DO NOT** touch or lean against hot exhaust pipes or engine block.
- **DO NOT** clean air filter with gasoline or other types of low flash point solvents.
- **DO NOT** remove engine coolant cap while engine is hot.
- **DO NOT** operate the unit without a functional exhaust system. Prolonged exposure to sound levels in excess of 85 DBA can cause permanent hearing loss. Wear hearing protection when working around a running engine.
- Keep hands, feet and loose clothing away from moving parts on the pump and engine.
- Keep area around exhaust pipes and radiator free of debris to reduce the chance of an accidental fire.
- Batteries contain sulfuric acid which can cause severe injury or death. Sulfuric acid can cause eye damage, burn flesh or eat holes in clothing. Protective eye wear and clothing are necessary when working on or around the battery. Always disconnect the NEGATIVE (-) battery cable from the corresponding terminal before performing any service on the engine or other components.
- Shut down the engine if any of the following conditions exist during operation:
 1. Noticeable change in engine speed.
 2. Loss of pumping output.
 3. Sparking occurs.
 4. Engine misfires or there is excessive engine vibration.

SERVICE SAFETY



Only a qualified electrician should troubleshoot or repair electrical problems occurring in this equipment.

- Before servicing the trash pump, make sure the engine start switch is turned to OFF and the negative terminal on the battery is disconnected. **NEVER** perform even routine service (oil/filter changes, cleaning, etc.) unless all electrical components are shut down.
- **NEVER** service electrical components if clothing or skin is wet. If the unit is stored outside, check the engine for any moisture and dry the unit before use.
- **NEVER** open the radiator cap or oil drain plug while the engine is running or before the engine has cooled down. Pressurized coolant and hot engine oil can cause severe burns. Allow the engine to cool completely before attempting any service work.
- **NEVER** attempt to modify the engine, pump or related components.
- **NEVER** wash the unit with a power washer or high pressure hose.
- Keep hands, feet, hair and loose clothing away from moving parts.
- Replace all guards and safety devices immediately after servicing.

- Replace all missing and hard-to-read labels. Labels provide important operating instructions and warn of dangers and hazards.
- Make sure slings, chains, hooks, ramps, jacks, and other types of lifting devices are attached securely and have enough weight-bearing capacity to lift or hold the equipment safely. Always remain aware of the position of other people around you when lifting the equipment.

TOWING SAFETY



Towing a trailer requires care! Both the trailer and vehicle must be in good condition and securely fastened to each other to reduce the possibility of an accident. Also, some states require that large trailers be registered and licensed. Contact your local Department of Transportation office to check on license requirements for your particular unit.

- Check that the hitch and coupling on the towing vehicle are rated equal to, or greater than, the trailer's "gross vehicle weight rating" (GVWR).
- Check tires on trailer for tread wear, inflation, and condition.
- Inspect the hitch and coupling for wear or damage. **DO NOT** tow trailer using defective parts!
- Make sure the trailer hitch and the coupling are compatible. Make sure the coupling is securely fastened to the vehicle.
- Connect safety chains in a crossing pattern under the tongue and attach the breakaway cable **TO THE REAR BUMPER OF THE TOWING VEHICLE**. Do not attach the cable to the trailer hitch.
- Make sure directional and brake lights on the trailer are connected and working properly.
- Check that all lug nuts holding wheels on are tight and that none are missing.
- Maximum recommended speed for highway towing is 45 m.p.h. Recommended off-road towing speed is not to exceed 10 m.p.h. or less depending on terrain.

The trailer is equipped with hydraulic surge brakes or electric surge brakes. Check the operation of the brakes by braking the vehicle at a slow speed before entering traffic. Both the trailer and the vehicle should brake smoothly. If the trailer seems to be pushing, check the level in the surge brake fluid reservoir.

When towing, maintain extra space between vehicles and avoid soft shoulders, curbs and sudden lane changes. If you have not pulled a trailer before, practice turning, stopping, and backing up in an area away from heavy traffic.

A film of grease on the coupler will extend coupler life and eliminate squeaking. Wipe the coupler clean and apply fresh grease each time the trailer is towed.

REPORTING TRAILER SAFETY DEFECTS

If you believe your trailer has a defect which could cause a crash or could cause injury or death, you should immediately inform the National Highway Traffic Safety Administration (NHTSA) in addition to notifying Magnum Products LLC.

If NHTSA receives similar complaints, it may open an investigation; and if it finds that a safety defect exists in a group of vehicles, it may order a recall and remedy campaign. However, NHTSA cannot become involved in an individual problem between you, your dealer, or Magnum Products LLC.

















To contact NHTSA, you may either call the Auto Safety Hotline toll-free at 1-888-327-4236 (TTY:1-800-424-9153), go to <http://www.safercar.gov>; or write to:

Administrator
NHTSA
1200 New Jersey Avenue S.E.
Washington, DC 20590

You can also obtain other information about motor vehicle safety from <http://www.safercar.gov>.

SAFETY SYMBOL SUMMARY

This equipment has been supplied with numerous safety and operating decals. These decals provide important operating instructions and warn of dangers and hazards. Replace any missing or hard-to-read decals and use care when washing or cleaning the unit. Decal placement and part numbers can be found in the parts manual. Below is a summary of the intended meanings for the symbols used on the decals.

 <p>Safety alert symbol; Used to alert you to potential personal injury hazards.</p>	 <p>Asphyxiation hazard; Operate in well ventilated area.</p>
 <p>Hot surface(s) nearby.</p>	 <p>Hazardous voltage. Disconnect battery before servicing.</p>
 <p>Belt/entanglement hazard; Keep body parts clear of this area.</p>	 <p>Anchor/tie down point.</p>
 <p>Rotating fan hazard; do not operate without guards in place. Keep body parts clear of this area.</p>	 <p>Burn/scald hazard; pressurized steam.</p>
 <p>Rotating impeller blade hazard; Keep body parts clear of this area.</p>	 <p>Use clean diesel fuel only.</p>
 <p>Moving parts can crush and cut; Keep body parts clear of this area.</p>	 <p>Remove negative battery cable before performing any service on unit.</p>
 <p>Stop engine before fueling.</p>	 <p>Read and understand the supplied operator's manual before operating unit.</p>
 <p>Hearing protection required while operating unit.</p>	 <p>Lift here only.</p>
 <p>Fire/explosion hazard; Keep open flames away from unit.</p>	

LOCATIONS AND CONTROLS

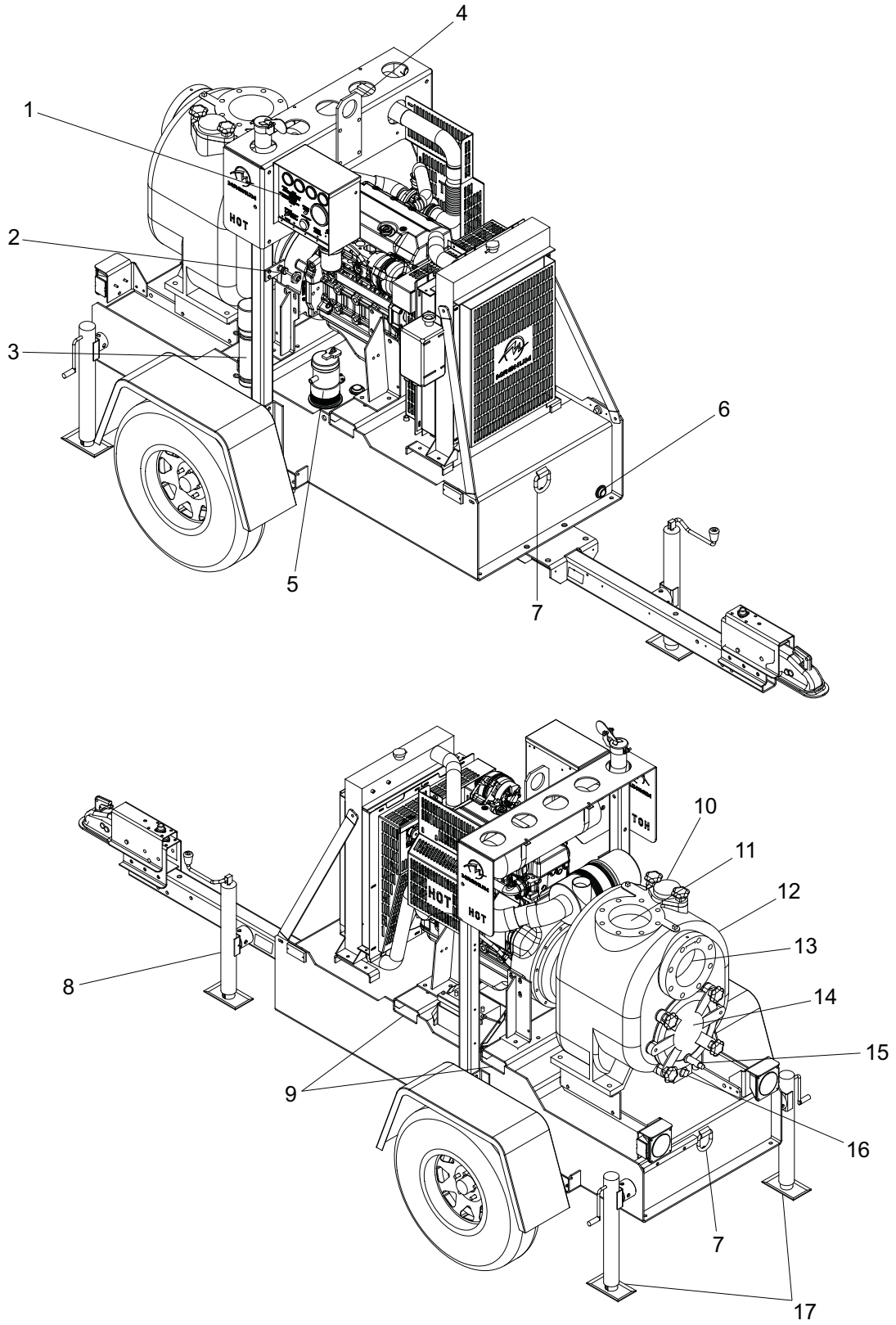

1. **CONTROL PANEL.** Controls and indicators for pump operation.
2. **HAND THROTTLE.** Controls pump engine speed.
3. **MANUAL HOLDER.** Storage for operator manuals.
4. **CENTRAL LIFT EYE.** Used for lifting the pump.
5. **FUEL FILL PORT.** Lockable port for filling the DIESEL fuel tank.
6. **FUEL TANK DRAIN.** Drain for fuel tank for cleaning and/or maintenance.
7. **TIE-DOWN RINGS.** Used to secure the pump for storage and/or transport.
8. **FRONT LEVELING JACK.** Used to level the pump on rough or uneven ground and to aid in attaching the pump to a tow vehicle.
9. **FORK LIFT POCKETS.** Used to move the pump when in skid configuration.
10. **PRIMING PORT.** Used to fill the pump volute with water.
11. **PUMP OUTLET (DISCHARGE) PORT.** Opening for discharge of liquids from the pump. Fittings can be threaded or bolted to the pump flange.
12. **PUMP VOLUTE (HOUSING).** Cast-iron housing for the pump mechanical components.
13. **PUMP INLET (SUCTION) PORT.** Opening for intake of liquids into the pump. Fittings can be threaded or bolted to the pump flange.
14. **PUMP CLEANOUT COVER.** Provides access to pump internals for cleaning and/or maintenance.
15. **PRESSURE RELIEF VALVE.** Safety device that will allow excess pressure to vent safely from the pump volute.
16. **DRAIN PLUG.** Allows for complete draining of the pump volute for storage and/or maintenance.
17. **REAR LEVELING JACKS.** Used to level the rear of the pump on rough or uneven ground.

Note: Use hoses and fittings that are specifically designed and sized for this type of equipment.

UNIT SERIAL NUMBER LOCATIONS

Refer to the locations illustrated to find the unit ID tag, and trailer ID tag on your unit. Important information, such as the unit serial number, model number and Vehicle Identification Number (V.I.N.) for your trailer are found on these tags. Record the information from these tags, so it is available if the tags are lost or damaged. When ordering parts or requesting technical service information, you may be asked to specify this information.

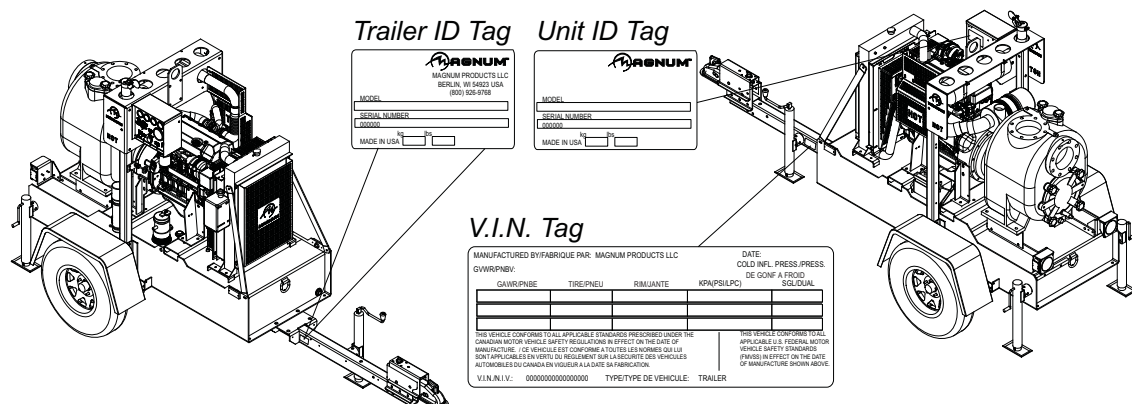

SPECIFICATIONS

Read this manual carefully before attempting to use this equipment. The potential for property damage, personal injury or death exists if this equipment is misused or installed incorrectly. Read all of the manuals included with this unit. Each manual details specific information regarding items such as set up, use and service requirements. *Specifications are subject to change without notice.*

MAGNUM MODEL	MTP4000S	MTP6000S
Engine:		
Make/Brand, Model	John Deere, PE4024TF281	John Deere, PE5030TF270
Type	Diesel, liquid cooled, 4-stroke	Diesel, liquid cooled, 4-stroke
Displacement in ³ (L)	149 (2.4)	149 (2.4)
Cylinders - qty	4	5
Eng Rated Speed rpm	2800	2800
Eng Pwr @ Rated Speed - Int. hp (kW)	66.0 (49.3)	75.0 (56.2)
Eng Pwr @ Rated Speed - Cont. hp (kW)	56.0 (41.8)	64.0 (47.8)
Eng Operating Speed rpm	2000	1800
Eng Pwr @ Oper. Speed - Int. hp (kW)	59.0 (43.6)	63.0 (47.0)
Eng Pwr @ Oper. Speed - Cont. hp (kW)	50.0 (37.1)	54.0 (39.9)
Fuel Consumption - 100% load gph (Lph)	2.0 (7.6)	2.8 (10.6)
Battery Type - Group Number	24	24
Battery Voltage (Quantity per Unit)	12V (1)	12V (1)
Battery Rating	720 CCA	720 CCA
Alternator Rating		70A
Pump:		
Make/Brand	Pioneer Pump Inc.	Pioneer Pump Inc.
Model	ES4	ES6
Fitting Size	4" NPTF	6" NPTF
Impeller Material	ASTM A536 Ductile Iron	ASTM A536 Ductile Iron
Impeller Diameter in (mm)	9.75 (248)	11.50 (292)
Shaft Material	17-4 PH Stainless Steel	17-4 PH Stainless Steel
Volute Material	ASTM A48 Gray Iron	ASTM A48 Gray Iron
Wear Plate Material	Steel with Stainless Hardware	Steel with Stainless Hardware
Pump Set (Engine/Pump):		
Maximum Diameter of Solids in (mm)	3.0 (76.2)	3.0 (76.2)
Maximum Pump Output gpm (Lpm)	1150 (4353)	1720 (6510)
Maximum Lift Suction ft (m)	25 (8)	24 (7)
Maximum Operating Speed rpm	2000	1800
Total Dynamic Head ft (m)	140 (42)	135 (41)
Sound dB(a) 23 ft. @ prime	79	78
Dimensions:		
Skid Mounted in (m)	82 x 35 x 60 (2.08 x .089 x 1.52)	82 x 35 x 60 (2.08 x .089 x 1.52)
Trailer Mounted in (m)	138 x 57 x 78 (3.51 x 1.45 x 1.98)	138 x 57 x 78 (3.51 x 1.45 x 1.98)
Weights:		
Dry Weight, Skid Mounted	2407 (1091)	2849 (1292)
Operating Weight, Skid Mounted	3199 (1451)	3641 (1652)
Dry Weight, Trailer Mounted	2957 (1341)	3399 (1542)
Operating Weight, Trailer Mounted	3749 (1701)	4191 (1901)
Capacities:		
Fuel Tank Volume gal (L)	110 (416)	110 (416)
Usable Fuel Volume gal (L)	95 (360)	95 (360)
Coolant (incl. engine) qt (L)	11.0 (10.4)	11.0 (10.4)
Oil (incl. filter) qt (L)	8.5 (8.0)	11.8 (11.2)
Maximum Run Time hrs	48	34
Trailer:		
Number of Axles	1	1
Capacity - Axle Rating lbs (kg)	5000 (2268)	5000 (2268)
Tire Size in	15	15
Brakes	Surge	Surge
Hitch - Standard	2" Ball	2" Ball
Maximum Tire Pressure psi	65	65

SPECIFICATIONS ARE SUBJECT TO CHANGE WITHOUT NOTICE.

MAIN CONTROL PANEL

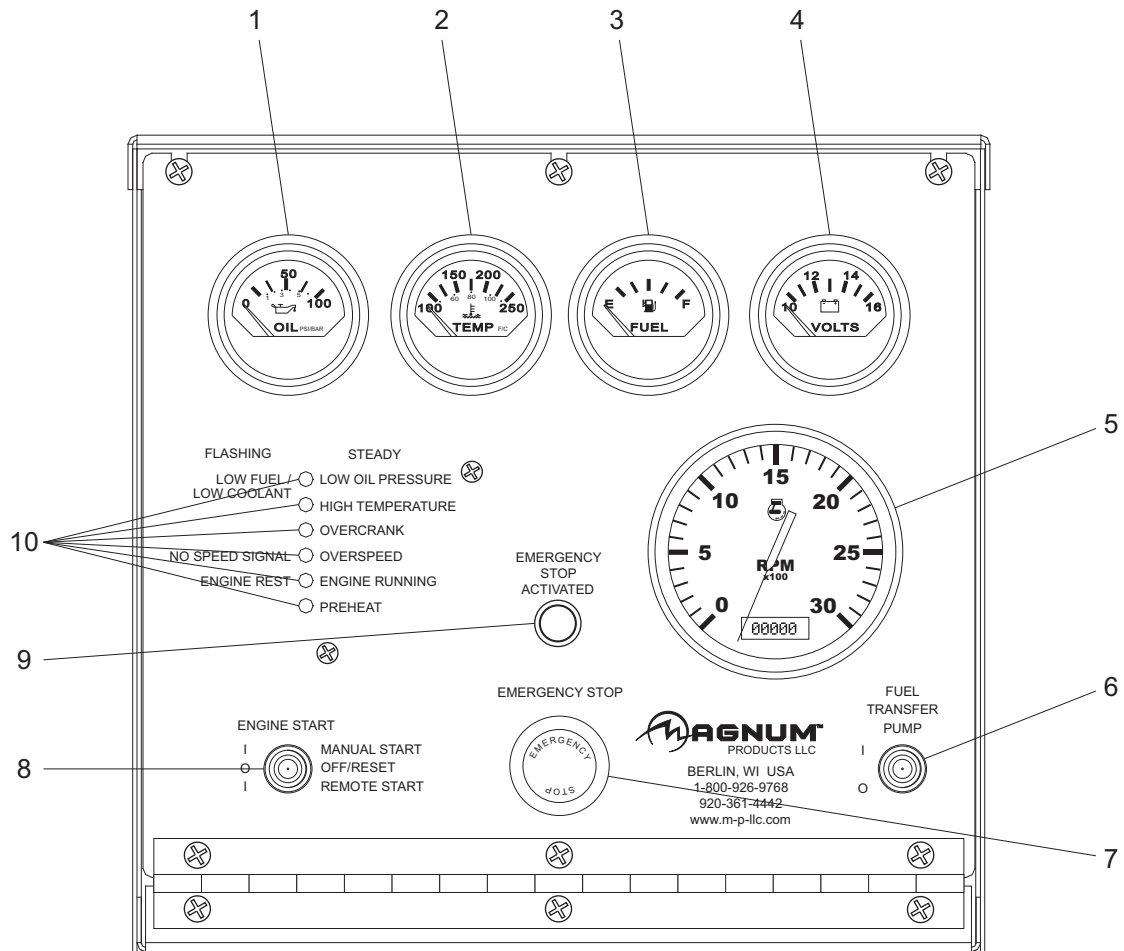

1. **ENGINE OIL PRESSURE GAUGE.** Displays engine oil pressure. Typical range is 30-80 psi.
2. **ENGINE COOLANT TEMPERATURE GAUGE.** Displays engine coolant temperature. Typical range is 180-210°F.
3. **FUEL LEVEL GAUGE.** Displays the amount of fuel remaining in the fuel tank.
4. **DC VOLTAGE GAUGE.** Displays DC voltage of the engine starting battery. Typical range is 12-14 volts.
5. **ENGINE TACHOMETER/HOUR METER.** Displays engine speed in revolutions per minute (RPM) and keeps track of engine hours for service.
6. **FUEL TRANSFER PUMP SWITCH.** Switch for optional fuel transfer pump for extended pump operation.
7. **EMERGENCY STOP SWITCH.** Stops engine in case of emergency by cutting power to the fuel solenoid.
8. **ENGINE START SWITCH.** Used to start and stop the pump engine or to allow for remote starting of the pump by a dry-contact closure type of switch.
9. **EMERGENCY STOP ACTIVATED LIGHT.** Notifies operator that the emergency stop is activated.
10. **CONTROL PANEL LEDs.** Indicates various engine operating parameters and faults. These LEDs either flash or are in a steady state.

CONTROL PANEL LEDS

FLASHING		STEADY
LOW FUEL / LOW COOLANT	●	LOW OIL PRESSURE
	●	HIGH TEMPERATURE
	●	OVERCRANK
NO SPEED SIGNAL	●	OVERSPEED
ENGINE REST	●	ENGINE RUNNING
	●	PREHEAT

FLASHING LEDS

- **LOW FUEL / LOW COOLANT:** Indicates a low fuel level or low coolant level shutdown (optional).
- **NO SPEED SIGNAL:** Indicates a pump engine shut down due to a loss of signal from the engine's magnetic pickup. Refer to the "Troubleshooting" section on page 21 for possible causes.
- **ENGINE REST:** Indicates the engine has paused between starting attempts.

STEADY STATE LEDS

- **LOW OIL PRESSURE:** Indicates a pump engine shut down due to low engine oil pressure. Refer to the "Troubleshooting" section on page 21 for possible causes.
- **HIGH TEMPERATURE:** Indicates a pump engine shut down due to the coolant temperature exceeding 235° F. Refer to the "Troubleshooting" section on page 21 for possible causes.
- **OVERCRANK:** Indicates the pump engine failed to start after three attempts. Refer to the "Troubleshooting" section on page 21 for possible causes.
- **OVERSPEED:** Indicates shutdown due to the pump engine running too fast. Refer to the "Troubleshooting" section on page 21 for possible causes.
- **ENGINE RUNNING:** Indicates proper operation of the pump engine.
- **PREHEAT:** Indicates operation of the engine's glow plugs during the engine starting procedure.

PRE-USE CHECKPOINTS

Before using the pump, be sure to check the following:

- Place the pump as close as possible to the liquid being pumped, keeping the number of hose sections and couplings to a minimum. The pump should be the highest point between the intake and outlet section of the hoses.
- Make sure the ground is firm and as level as possible.
- Check the pump discharge area; make sure it will not erode the material under the pump or damage any nearby structures.
- Make sure all hose couplings are of the same size and type.

▲ WARNING

The pump is designed to handle water and/or other liquids containing some slurries and other entrapped solids up to a certain diameter (see the "SPECIFICATIONS" section on page 10 for the correct diameter). It MUST NOT be used to pump volatile, corrosive or flammable materials that may damage the pump, cause pump failure or result in explosion!

PUMP SET UP

1. Disconnect the pump from the tow vehicle by turning the tongue jack clockwise to raise the tongue from the hitch. Disconnect all safety chains, surge brake cables and the trailer wiring harness.
2. Lower the rear leveling jacks from the travel position. Turn the jack handles clockwise until the leveling feet are in firm contact with the ground. Adjust the jacks until the pump is as level as possible.
3. Attach fittings to both the intake and outlet openings of the pump, making sure they match the fittings on the hoses. Make sure a gasket/seal is in place between the pump volute and the flange on the fitting being attached. Tighten all hardware completely to ensure an airtight seal. Threaded fittings require the use of pipe thread sealant.
4. Attach a rigid fill hose to the intake (suction) side of the pump. **DO NOT** use an intake hose that has a larger diameter than the intake opening of the pump. The pump may not prime and suction velocity may be too low to allow suspended solids to travel through the hose. Make sure the o-ring seal is present in the fitting on the pump before attaching the fitting.
Note: *Lubricate the o-ring seal with grease to ensure an airtight seal.*
5. Attach a rigid intake screen or strainer to the end of the fill hose before placing it in the liquid. This will prevent large items or excessive trash from entering the pump housing. The screen must have enough openings to equal 4 times the area of the intake hose ($6" \times 3.14 = 18.84 \text{ sq.in} \times 4 = 75.36 \text{ sq.in.}$).
6. Attach a flexible hose to the outlet (discharge) side of the pump. Make sure the o-ring seal is present in the fitting on the pump before attaching the fitting. **Note:** *Lubricate the o-ring seal with grease to ensure an airtight seal.*
7. Check the intake and outlet hoses for and sharp bends or kinks that may restrict pump flow before proceeding. The intake hose should slope upwards toward the pump to avoid development of air pockets in the hose which may lead to pump cavitation. Keep the hoses as straight as possible.

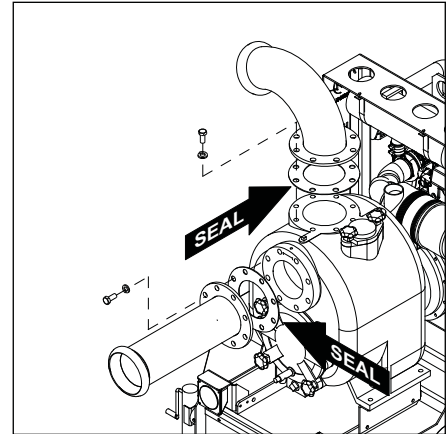

8. Prime the pump by removing the cover from the top of the pump volute and filling the pump casing with water. **Note:** *The casing will only fill to the bottom of the intake fitting, not to the top of the volute.* Replace the cover and tighten the clamp screws hand tight.

⚠ WARNING

Never open the priming cover on a pump that is hot or that has been operated recently. Extreme pressure may have built up inside the pump volute, causing injury.

The pump is now ready for use.

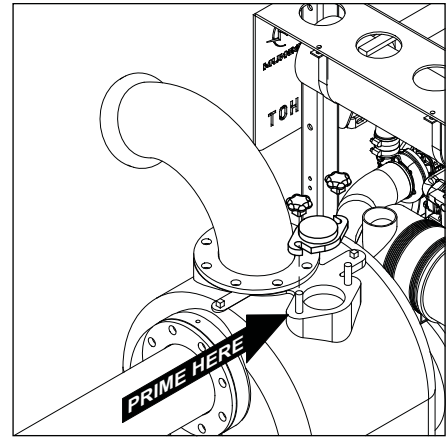

STARTING THE PUMP

Before starting the pump, be sure to check the following:

- Make sure all hose couplings, covers and plugs are tight.
- Check the oil level in the sight glass(es) on the connection between the engine flywheel and pump volute. The oil level should be in the middle of the sight glass.
- Check the engine oil level, coolant level and fuel level.
- Make sure the engine starting battery is connected.

1. Make sure the Emergency Stop switch is pulled out (deactivated).

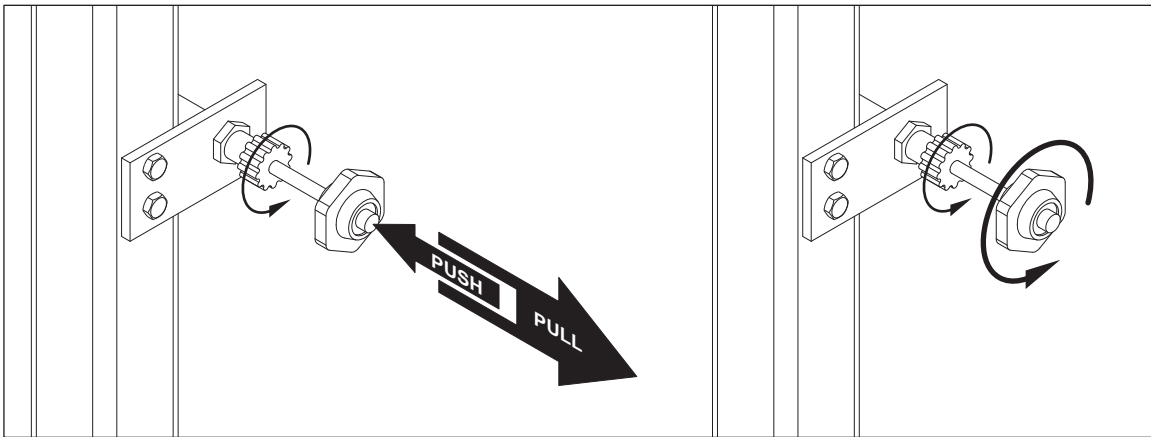

2. Push the Engine Start Switch up to the MANUAL START position. The PREHEAT LED on the control panel will light up to indicate activation of the engine glow plugs. Once sufficient time has passed, the engine should crank, start and run, slowly building up speed.
3. Allow the engine to run until it reaches a constant speed. Once it is running smoothly, the engine speed can be adjusted by the throttle, located above the fuel fill port.
To adjust the engine speed:
 - A. Loosen the locking ring on the throttle, located next to the mounting bracket, by turning counterclockwise.
 - B. Push and hold the center button on the throttle:
 - PULL the throttle out to INCREASE engine speed.
 - PUSH the throttle in to DECREASE engine speed.
 - C. Fine engine speed adjustment can be made by turning the throttle clockwise or counterclockwise.
 - D. Once the desired engine speed has been attained, lock the throttle by turning the locking ring clockwise.

4. The pump should self prime and begin to discharge liquid within minutes. A high suction lift or low engine speed will require a longer time to prime and pump. If the pump output is low or irregular, shut the engine off and allow the pump to cool before proceeding to the PUMP TROUBLESHOOTING section.
5. Use the engine throttle to adjust the pump flow. Several factors can influence pump output:
 - The temperature, viscosity amount of entrapped solids in the liquid being moved.
 - The length, diameter and number of bends of the intake and outlet hoses.
 - The total suction height (lift) of the pump.
 - The altitude above sea level where the pump is operating.

⚠ WARNING

Never adjust the pump flow by attaching a valve to the intake or outlet side of the pump. Restricting the flow in this way can cause the pump to overheat, creating extreme pressure inside the pump volute. Explosion of the pump volute and serious personal injury may result!

6. As the pump operates, avoid running the intake side of the pump dry. Air from the intake side of the pump may cause cavitation, causing damage to the pump impeller. The intake hose must be kept 4-5 times the hose diameter (4-5 x 6" = 24-30") below the surface of the liquid being pumped.
7. Use the table below for approximate flow rates for the 4" pump.

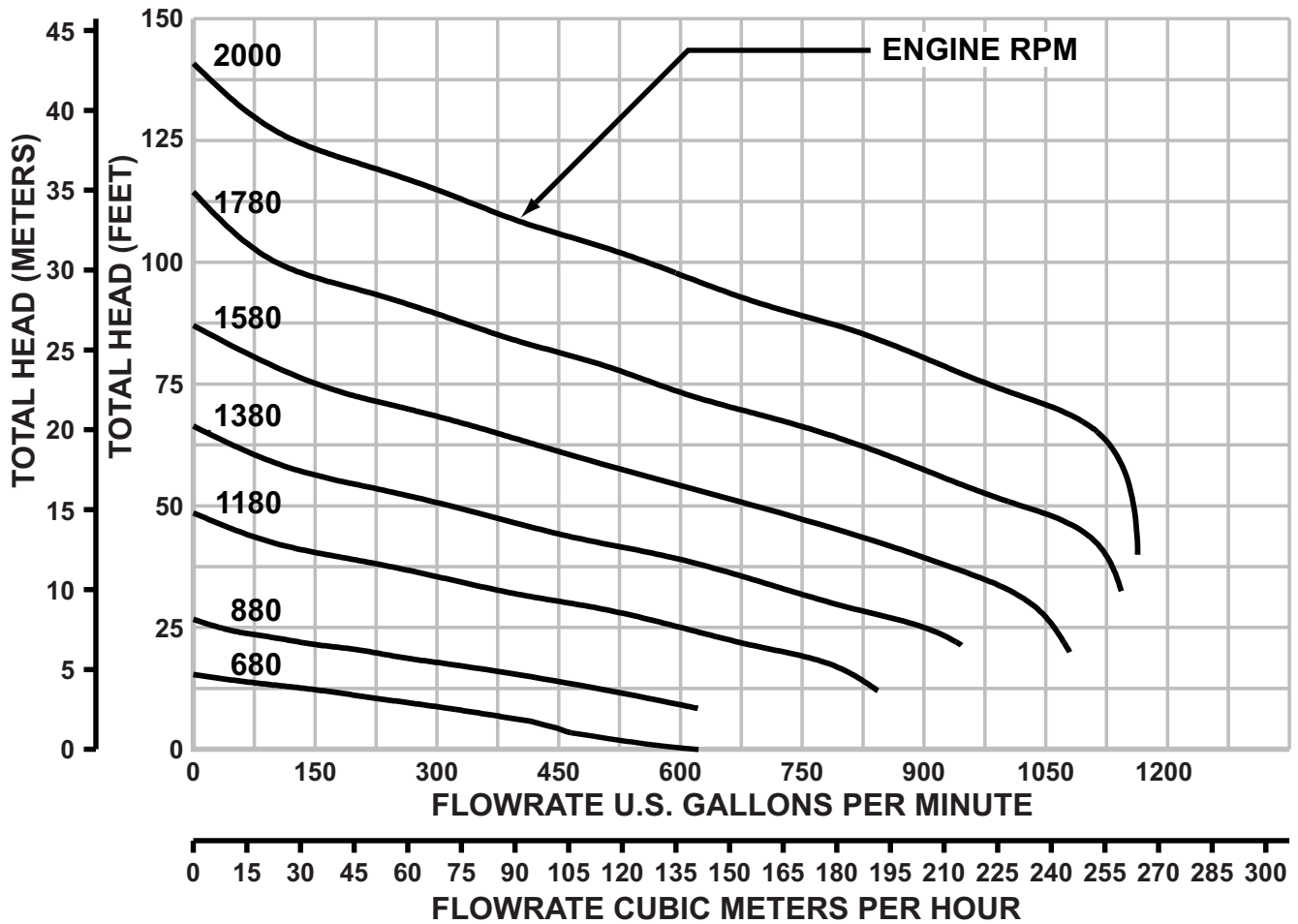

8. Use the table below for approximate flow rates for the 6" pump.

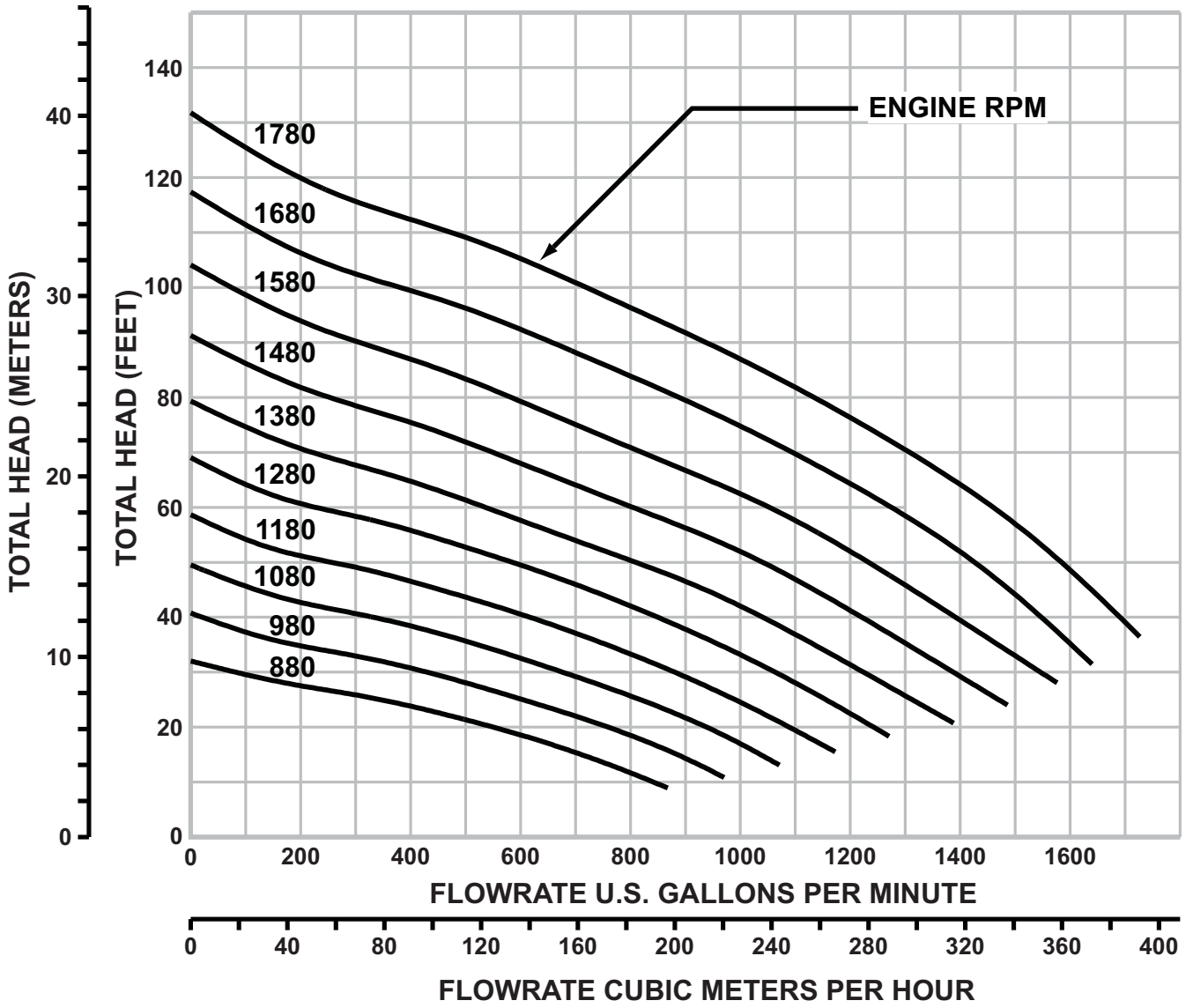

SUCTION SPECIFICATIONS

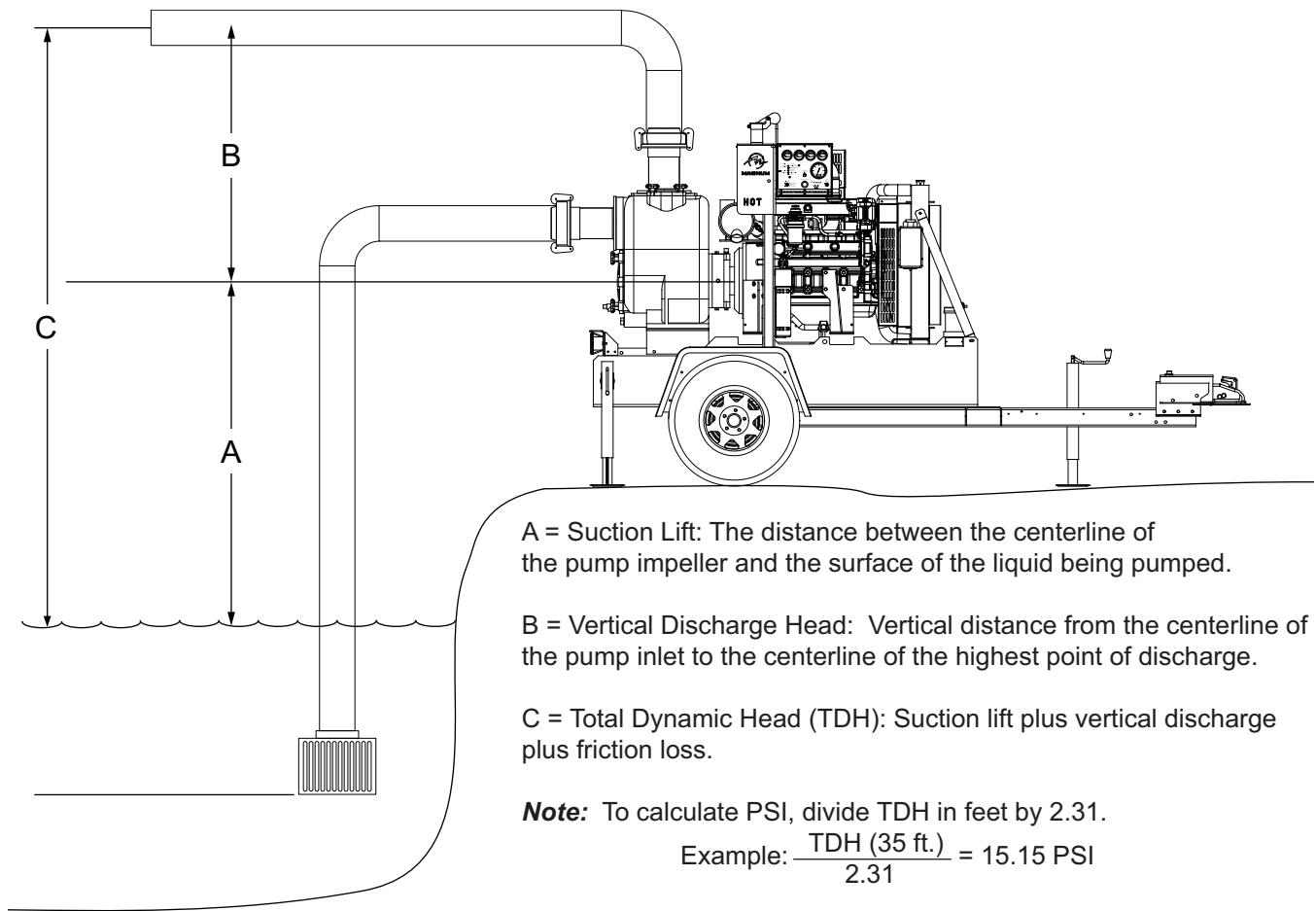

STOPPING THE PUMP

1. Reduce the engine speed by adjusting the engine throttle.
2. Allow the engine to idle briefly before switching the engine start switch to the center (OFF) position.

NOTICE

Do not use the Emergency Stop switch unless absolutely necessary. Stopping the pump suddenly may cause shock waves to be transmitted back to the pump volute, causing pump damage. To activate the emergency stop, push the stop switch in. To deactivate the switch, pull the switch out.

AUTOMATIC SHUTDOWN

The pump is equipped with a low oil pressure and a high temperature automatic shutdown system. This system will automatically shut off the fuel supply to stop the engine if oil pressure drops too low or the engine exceeds normal operating temperature. Return the engine start switch to the "OFF" position to reset the controller; restart the pump engine after you have determined the cause of the shutdown. Refer to the ENGINE FAULT SHUTDOWN TROUBLESHOOTING section for more information.

REMOTE/AUTO STARTING

The pump can be configured to start automatically by the addition of dry-contact closure float level switches. These connections are found on the control panel next to the emergency stop button. Both float switches must be connected for automatic starting to occur. Contact Magnum Products' Technical Service Department at 1-800-926-9768 or 1-920-361-4442 for more information.

ENGINE AND PUMP MAINTENANCE

Poorly maintained equipment can become a safety hazard! In order for the equipment to operate safely and properly over a long period of time, periodic maintenance and occasional repairs are necessary. NEVER perform even routine service (oil/filter changes, cleaning, etc.) unless the engine start switch is turned to off “O” and the negative (-) cable on the battery is disconnected. Attach a “DO NOT START” sign to the control panel. This will notify everyone that the unit is being serviced and will reduce the chance of someone inadvertently trying to start the unit.

Never wash the unit with a high pressure hose or with any kind of power washer. Never wash the engine block or fuel tank with a power washer or steam cleaner. Water may collect in the pump control panel or other electrical parts, causing damage.

ENGINE BREAK-IN REQUIREMENTS

Note: During the first 20 hours of operation, avoid long periods of low engine speed or sustained maximum engine speed. The engine is supplied with engine break-in oil from the factory. Extra care during the first 100 hours of engine operation will result in better performance and longer engine life. **Note: DO NOT exceed 100 hours of operation with the break-in oil.** Operate the engine at high engine speeds (60-90% of maximum) as much as possible. If the engine has spent significant time at idle, constant speeds and/or light load or if makeup oil is required, a longer break-in period may be needed. Consult the engine OPERATION AND MAINTENANCE MANUAL for a full description of necessary procedures on the addition of break-in oil and extension of the break-in period.

OIL SIGHT GLASS

Check the mechanical seal and bearing oil sight glasses daily. Top off the mechanical seal and bearing oil level through their oil fill ports. **Use only ISO Viscosity Grade 32, turbine-quality circulation oil.**

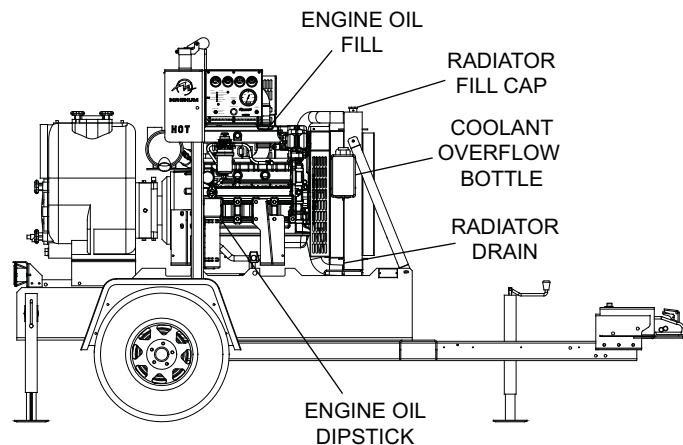
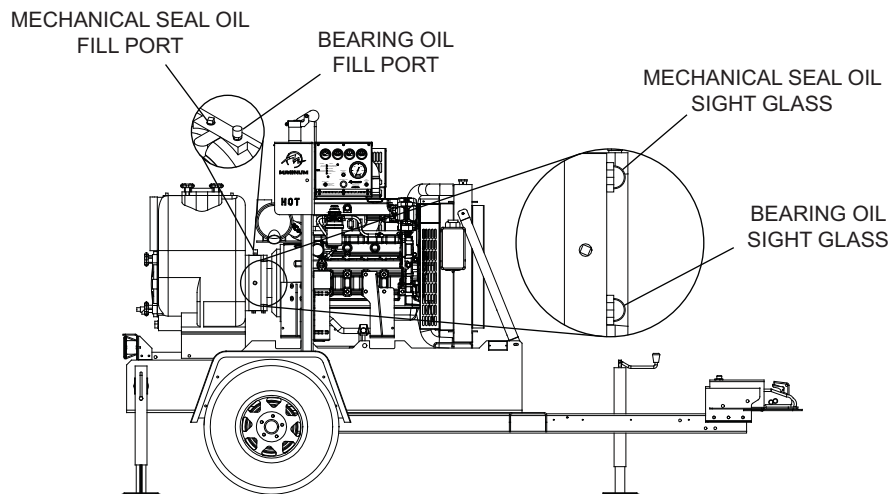

DAILY WALK AROUND INSPECTION

Look for conditions that could hinder performance or safety, such as (but not limited to) oil/coolant/fuel leakage, blocked vents, loose/missing hardware and electrical connections.

Visually inspect the fan belt for cracks, fraying, stretching and that the belt is properly seated in pulley grooves. Replace the belt according to the manufacturer's recommendations.

Note: At the 500 hour/12 month service interval, it is recommended that the belt be removed and checked for wear. While the belt is removed, inspect pulleys and bearings. Rotate and feel for hard turning or unusual sounds. If pulleys or bearings need replacement contact John Deere.

Note: Failure to perform a daily inspection may result in serious damage to the prime mover.

BELT TENSION

John Deere engines use two types of belt tensioners: manual and automatic. Adjust the belt using the manual tensioner according to the manufacturer's specifications. The automatic tensioner cannot be adjusted or repaired and is designed to maintain proper tension over the belt's life. Units with the automatic belt tensioner must be inspected according to the manufacturer's specifications.

MAINTENANCE SCHEDULE

Use the schedule in the table below as a guide for regular maintenance intervals.

Maintenance Action	Check Daily	First 50 Hours	Every 100 Hours	Every 250 Hours	Every 500 Hours	Every 2000 Hours
Check Engine Oil Level	■					
Check Engine Coolant Level	■					
Check Fuel Level	■					
Check Pump Seal Sight Glass	■					
Check for Fuel Leaks	■					
Check for Coolant Leaks	■					
Check Fan Belt Tension	■					
Check Tire Inflation	■					
Check Flange Fitting Hardware	■					
Change Engine Oil and Filter		■		■		
Check Fan Belt Condition			■			
Clean Fuel Filter			■			
Check Condition of Wear Plate			■			
Check Condition of Volute Seals				■		
Check Exhaust System Components				■		
Replace Fuel Filter Element				■		
Clean Air Filter Element, Replace If Necessary					■	
Service Battery					■	
Flush Cooling System					■	
Clean Crankcase Vent Tube					■	
Check Compressor Mounting Hardware					■	
Replace Fan Belt					■	
Replace Cooling System Hoses						■
Pressure Test Cooling System						■
Check Engine Valve Clearance						■
Check Flex Coupling Condition						■
Check Pump to Engine Hardware						■

TOWING THE TRAILER

1. Use the jack to raise or lower the trailer onto the hitch of the towing vehicle. Lock the hitch coupling and attach the safety chains or cables to the vehicle. Release the jack locking pin and rotate the jack into the travel position. Make sure the locking pin snaps into place.
2. Connect any trailer wiring to the tow vehicle. Check for proper operation of the stop and signal lights.
3. Check for proper inflation of the trailer tires. See "SPECIFICATIONS" section on page 10 for appropriate tire pressure.
4. Check the wheel lugs. Tighten or replace any that are loose or missing. If a tire has been removed for axle service or replacement, tighten the lugs in the order shown to the following specifications:
 - A. Start all lug nuts by hand.
 - B. First pass tighten to 20-25 Ft-Lbs (27-33 Nm).
 - C. Second pass tighten to 50-60 Ft-Lbs (67-81 Nm).
 - D. Third pass tighten to 90-120 Ft-Lbs (122-162 Nm).

After the first road use, retorque the lug nuts in sequence.

5. Maximum recommended speed for highway towing is 45 mph. Recommended off-road towing speed is not to exceed 10 mph or less depending on terrain.

TRAILER WHEEL BEARINGS

The trailer is equipped with a grease zerk fitting to allow lubrication of the wheel bearings without the need to disassemble the axle hub. To lubricate the axle bearings, remove the small rubber plug on the grease cap, attach a standard grease gun fitting to the grease zerk fitting and pump grease into the fitting until new grease is visible around the nozzle of the grease gun. Use only a high quality grease made specifically for lubrication of wheel bearings. Wipe any excess grease from the hub with a clean cloth and replace the rubber plug when finished. The minimum recommended lubrication is every 12 months or 12,000 miles; more frequent lubrication may be required under extremely dusty or damp operating conditions.

LIFTING THE PUMP

Only lift the pump with equipment rated for the weight of the pump. See the specifications on page 10 for approximate weights of the pump.

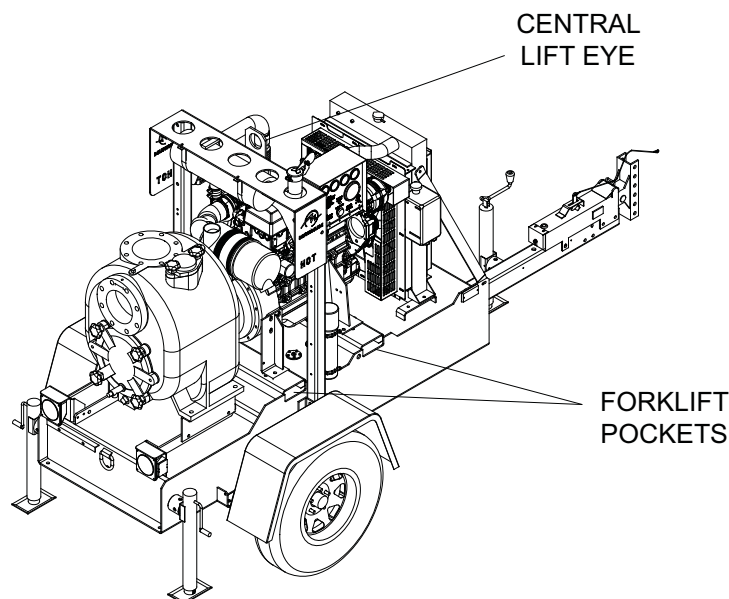

TROUBLESHOOTING

PUMP TROUBLESHOOTING		
SYMPTOM	POSSIBLE CAUSE	SOLUTION
Pump will not prime	Pump volute empty	Add water to pump volute
	Air leak in intake hose	Inspect intake hoses and couplings for damage or missing components and seals
	Air leak at pump housing	Inspect gaskets, seals and o-rings at pump intake flange, cleanout cover and priming port
	Engine speed too low	Increase engine speed
	Intake hose collapsed	Replace intake hose with a more rigid one
	Obstruction in intake hose	Inspect intake hose; remove any obstructions
	Intake insufficiently submerged	Lower intake hose
	Suction check valve damaged	Remove intake hose and inspect check valve through intake opening
	Suction lift too high	Relocate pump
Low pump output	Intake insufficiently submerged	Lower intake hose
	Air leak in intake hose	Inspect intake hoses and couplings for damage or missing components and seals
	Air leak at pump housing	Inspect gaskets, seals and o-rings at pump intake flange, cleanout cover and priming port
	Air trapped in intake hose	Relocate and/or straighten intake hose
	Engine speed too low	Increase engine speed
	Intake hose collapsed	Replace intake hose with a more rigid one
	Suction lift too high	Relocate pump
	Excess air in liquid	Allow liquid to settle
	Total head too high	Reduce inlet and outlet hose length
	Impeller obstructed	Remove pump cleanout cover and check pump volute for obstructions
	Worn pump components	Remove pump cleanout cover and check wear plate and impeller for wear or damage
Vibration and/or noise when pump is operating	Intake insufficiently submerged	Lower intake hose
	Air leak in intake hose	Inspect intake hoses and couplings for damage or missing components and seals
	Air leak at pump housing	Inspect gaskets, seals and o-rings at pump intake flange, cleanout cover and priming port
	Engine speed incorrect	Change engine speed
	Intake hose collapsed	Replace intake hose with a more rigid one
	Suction lift too high	Relocate pump
	Excess air in liquid	Allow liquid to settle
	Total head too high	Reduce inlet and outlet hose length
Impeller obstructed	Remove pump cleanout cover and check pump volute for obstructions	

TROUBLESHOOTING

PUMP TROUBLESHOOTING, CONTINUED		
SYMPTOM	POSSIBLE CAUSE	SOLUTION
Vibration and/or noise when pump is operating	Worn pump components	Remove pump cleanout cover and check wear plate and impeller for wear or damage
	Improper or low lubrication at mechanical pump seal	Stop pump, inspect oil level at mechanical seal sight glass
	Pump cavitation	Reduce engine speed, lower intake hose
	Worn pump bearings	Repair pump
Pump is overheating	Pump volute empty	Add water to pump volute
	Impeller obstructed	Remove pump cleanout cover and check pump volute for obstructions
	Worn pump components	Remove pump cleanout cover and check wear plate and impeller for wear or damage
	Improper or low lubrication at mechanical pump seal	Stop pump, inspect oil level at mechanical seal sight glass
	Worn pump bearings	Repair pump

ENGINE FAULT SHUTDOWN TROUBLESHOOTING		
SYMPTOM	POSSIBLE CAUSE	SOLUTION
Low oil pressure shutdown	Low oil level	Check oil level, replace as necessary
	Faulty oil pressure sender	Replace oil pressure sender
	Incorrect oil grade	Change engine oil, consult engine operating manual
	Worn oil pump	Consult engine operating manual
	Oil leak	Consult engine operating manual
High temperature shutdown	Low coolant level	Check coolant level, replace as necessary
	Faulty temperature sender	Replace temperature sender
	Coolant leaks	Consult engine operating manual, replace components as necessary
	Worn water pump	Consult engine operating manual
Overcrank shutdown	Pump engine will not start	Consult engine operating manual
Overspeed shutdown	Pump cavitation	Reduce engine speed, lower intake hose
	Air trapped in intake hose	Relocate and/or straighten intake hose
	Intake insufficiently submerged	Lower intake hose
	Air leak in intake hose	Inspect intake hoses and couplings for damage or missing components and seals
	Air leak at pump housing	Inspect gaskets, seals and o-rings at pump intake flange, cleanout cover and priming port
No speed signal shutdown	Engine magnetic pickup damaged or misaligned	Inspect magnetic pickup for damage/alignment
Low fuel shutdown	Low fuel level	Refill fuel tank with clean diesel fuel
Low coolant shutdown	Low coolant level	Allow engine to cool. Check coolant level in radiator. Add coolant until it is 3/4" below the filler neck.

TRAILER LIGHTS WIRING DIAGRAM

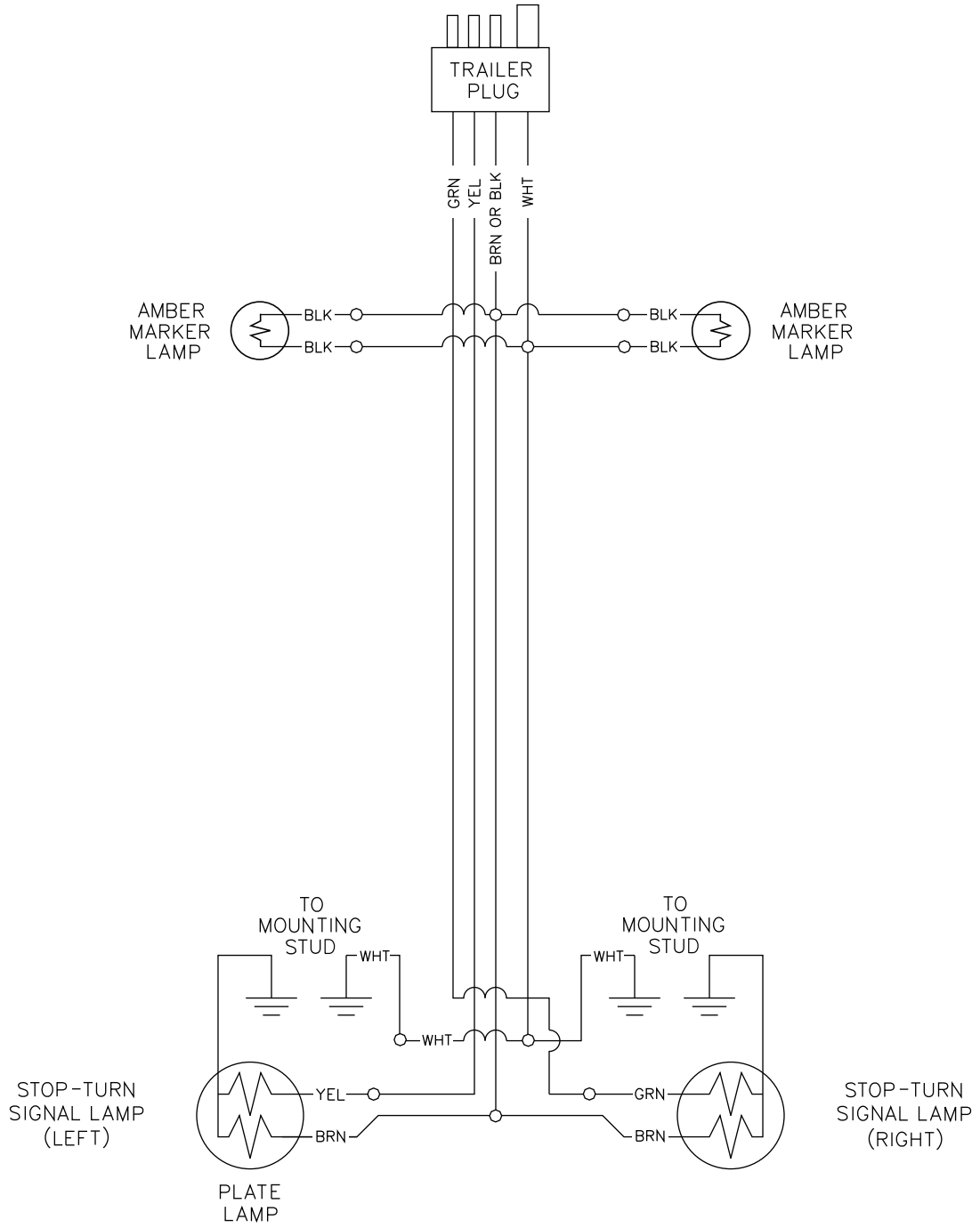

DC WIRING DIAGRAM

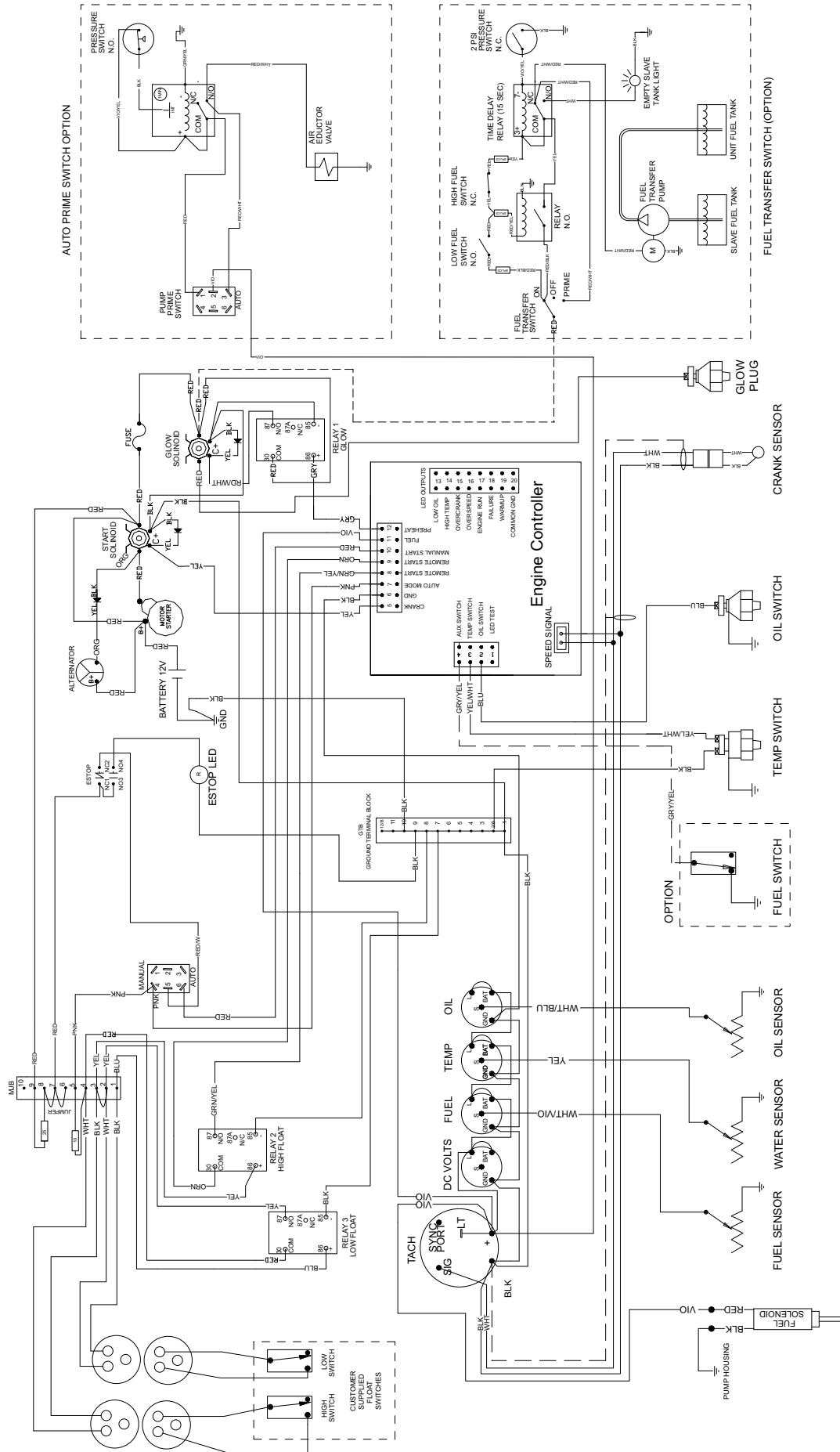

REV: J
PART NO: 41207
08.30.10